

CNC Machining Centres

Edgebanders

Beam Saws

Vertical Panel Saws

Material Handling



HOLZHER

Product Overview

Machine Program – Automation – Service





PERFECTING WOOD AND PLASTIC PROCESSING IS OUR PASSION

Our engineers are among the best in the world. Their visionary imagination and exceptional skill guarantee that our machines are the most powerful, most flexible and safest in our market sector. Customers appreciate our ability to develop and produce excellent, high-quality products quickly and at competitive prices. Integrated, networked solutions are crucial for machining wood and panels for a highly demanding market.

This is why HOLZ-HER offers a line of products matched to one another and always develops a complete product series, from an entry-level machine right up through all performance ranges to the comprehensive top models. All service activities and product training courses are planned in parallel to new products. This offers customers a complete range of services in addition to the new machine. Here emphasis is placed on practical solutions and greater customer benefit.

- We want to fully understand our customers and partners to optimize and increase their success with innovative products and services.
- Close contact with our dealers as well as customers, such as cabinet makers, interior architects and industrial workshops is one of HOLZ-HER's particular strengths.
- Providing above average performance in all areas, thinking of the future, continuity and consistency in development and design, perfection in production and intensive consulting in sales and service are HOLZ-HER's focal points.
- Recognizing and anticipating trends are key qualifications for strong companies like HOLZ-HER. This requires up-to-date qualifications from each and every employee. For this reason, HOLZ-HER places a great deal of emphasis on professional training for employees.



The WEINIG Group – Machines and Equipment for Processing Solid Wood and Derived Timber Products

Innovative, cutting-edge technology, comprehensive services and system solutions right on up to ready-to-use production facilities: The WEINIG Group is your partner for profitable processing of solid wood and derived timber products. WEINIG quality and efficiency provide you with a decisive advantage in competition, whether in the field of crafts or industry.

Our state-of-the-art production techniques at HOLZ-HER's production facilities in Voitsberg in the Austrian State of Steiermark are decisive for high quality, flexibility and economic production costs. Keeping core competencies for production in the company is one of HOLZ-HER's top priorities. This includes our own steel construction facilities with all technical equipment and our own prototype construction shop. Our customers can depend on HOLZ-HER machines right from the start as well as over their long service life.



» CNC Machines from HOLZ-HER: The Perfect Model for Every Application <

A HOLZ-HER CNC machining centre offers you virtually unlimited processing possibilities. They mean even furniture and components with complex designs can be produced economically and precisely.

- » **EPICON Series**
- » **DYNESTIC Series**
- » **EVOLUTION Series**

PROFESSIONAL CNC TECHNOLOGY PROVIDING UNLIMITED CAPABILITIES FOR PROCESSING WOOD AND SYNTHETIC MATERIALS

Investments in state-of-the-art CNC technology are hugely beneficial. Even furniture and components with complex designs can be produced economically and precisely. The HOLZ-HER CNC machining centers offer virtually unlimited possibilities for 3, 4 and 5 axis machining. Constructed for the most highly demanding work, solid and precise construction of all these machines represents the latest in modern and application-friendly industrial design.



True 300 mm workpiece height

Perfect for custom and highly variable processing on panel material and solid wood.



The Power Package in 5-Axis Technology

The compact, gimbal-mounted processing head guarantees precision production of furniture, staircases and shaped components with complex design. The powerful and fully interpolating machining head operates at speeds up to 24,000 rpm; its ceramic bearings and liquid cooling allow it to work under extremely high loads.

The special feature of the 18 kW spindle is the PRO-TORQUE technology, which automatically locks the A and C axes mechanically, resulting in extremely high stability to facilitate the use of extreme torque at the spindle.

THE UNIVERSAL GENIUS FOR YOUR SHOP

It is Time for the Next Generation in CNC Machining

It would be really difficult to imagine efficient production without CNC machining centres, even in smaller carpentry workshops. With the EPICON CNC series, HOLZ-HER offers high performance, universal geniuses, opening up completely new horizons in implementing user creativity. In addition to the convincing machining dimensions, the EPICON also includes an impressive array of hardware features. Step up to the next generation of CNC machining with the EPICON. The EPICON flexibility ensures optimal adaptation to your applications.

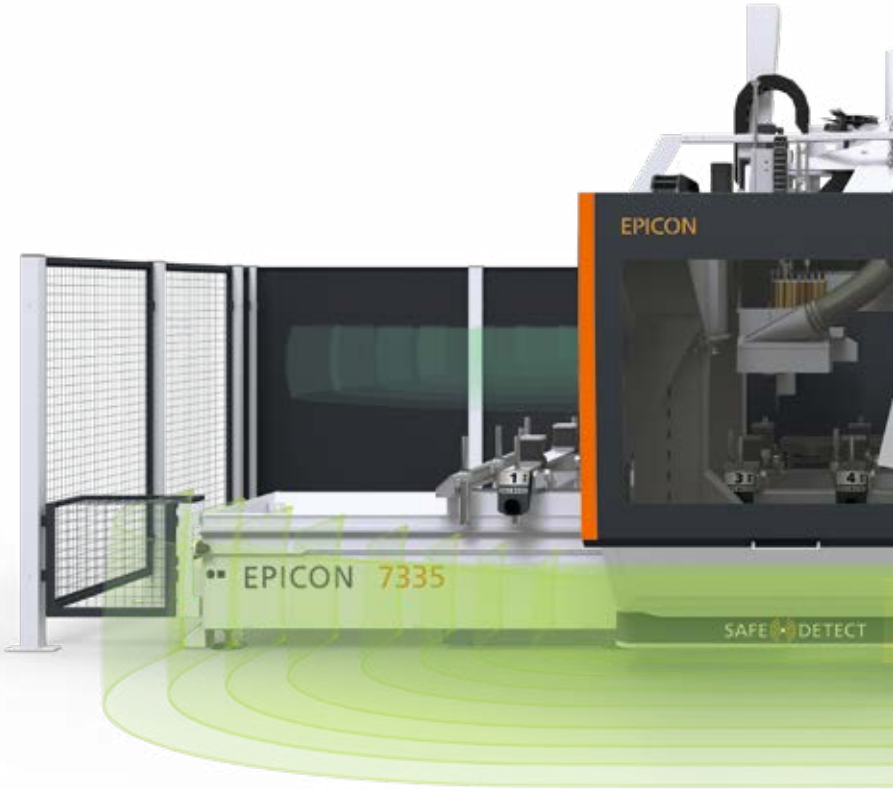

Highly Flexible Table Concepts



VISE LED Table

The ingenious solution for quickly setting up the console table, thanks to HOLZ-HER Visual Setting.



Synchro-Drive Table

Greater convenience is not possible. Synchronous, movable suction cups and consoles position themselves to fit any workpiece under software control.



SAFE DETECT

The space above the machine table as well as the area in front of the machine is monitored for perfect all-round protection. State-of-the-art sensor technology offers safety and freedom of motion for the operator thanks to automatic human detection with distance control. In addition a state-of-the-art guard fence prevents access to the machining centre's operating area at the side and rear.

EPICON 7335

- Machining dimensions in X direction: 3680/4580/5480/6380/7280 mm
- Machining dimensions in Y direction: 2100 mm
- True machining height: 300 mm (from top of suction cups)

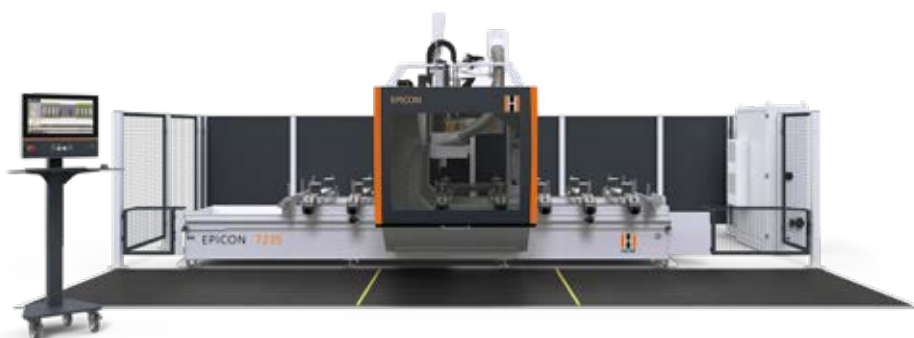

EPICON 7235

- Machining dimensions in X direction: 3680/4580/5480/6380/7280 mm
- Machining dimensions in Y direction: 1650 mm
- True machining height: 300 mm (from top of suction cups)

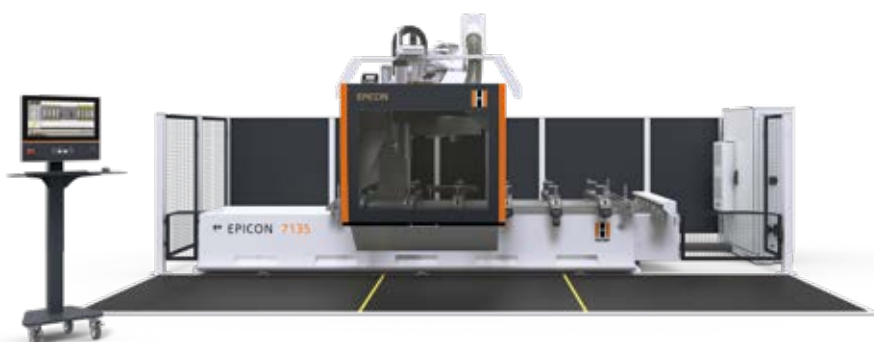

EPICON 7135

- Machining dimensions in X direction: 3680/4580/5480/6380/7280 mm
- Machining dimensions in Y direction: 1500 mm
- True machining height: 300 mm (from top of suction cups)



EFFICIENT PRODUCTION

Time Savings in Production with HOLZ-HER Nesting Technology

The nesting CNC machining centres allow panel materials to be machined and cut with optimized cutting patterns for minimum waste. The enormous versatility in its various equipment versions allows this CNC series to be adapted to any desired operating mode and highly differing degrees of automation. Dynamic, flexible and top quality in every respect – the DYNESTIC series from HOLZ-HER is the machining centre for complete panel machining using the nesting process.

NEXTEC 4.0 – The Local Solution for your Transparent Production control

With the NEXTEC 4.0 Network PC you can digitally connect your furniture planning in the office with your CNC machine. All CAD/CAM data compiled in the office with your planning software can be transferred to your machine in the shop using the Warehouse-Production-List. Digitization made simple: Realise your workshop of the future today.



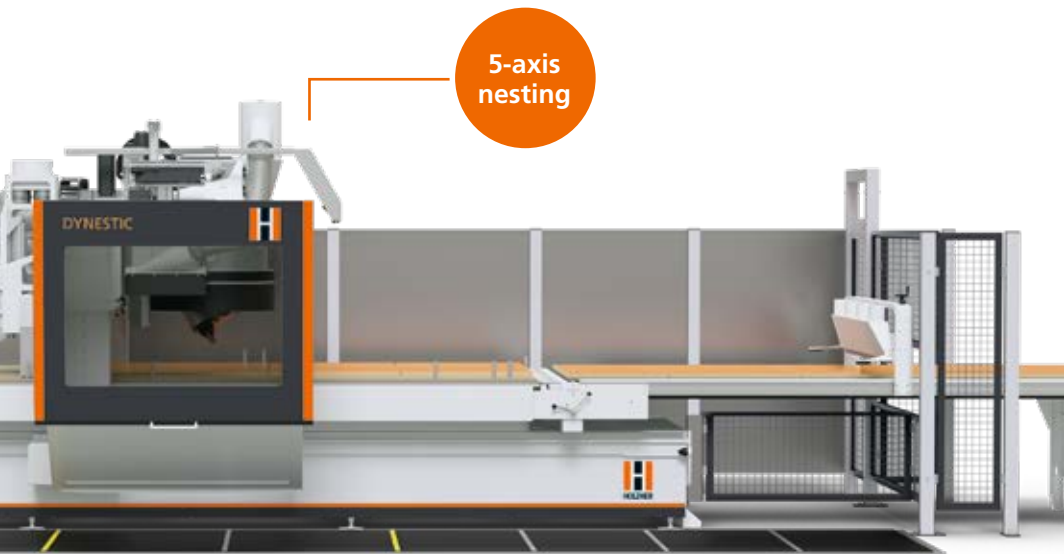

All models available as:

Classic Edition

Space-saving and versatile stand-alone solution

Push Edition

Increased panel throughput thanks to automatic discharge pusher

Automatic Edition

Seamless integration into your automatic panel storage system

Lift Edition

Standard features include lifting table for machining complete stacks of panels

Right-hand version

Various models also available as right-hand version – mirror-image machine configuration for special setup situations

DYNESTIC 7535

- Machining dimensions in X direction: 3100/3700/4600/6250 mm
- Machining dimensions in Y direction: 1600/2200 mm

DYNESTIC 7532

- Machining dimensions in X direction: 3100/3700/4600/6250 mm
- Machining dimensions in Y direction: 1600/2200 mm

3-axis High Speed Nesting



3 and 4-axis nesting



DYNESTIC 7505

- Machining dimensions in X direction: 3100/3700/6250 mm
- Machining dimensions in Y direction: 1600 mm

DYNESTIC 7507

- Machining dimensions in X direction: 3100/3700/4600 mm
- Machining dimensions in Y direction: 2200 mm

VERTICAL CNC PERFECTION

Efficiency in the Smallest of Spaces

The EVOLUTION Series offers you enormous versatility and flexibility in just barely 5 m² of floor space. Ideal for shops with little space, for CNC novices or shops requiring increased processing capacity. Regardless whether you use the EVOLUTION 7402 or the power version, the EVOLUTION 7405: There is a CNC machine for every user to satisfy custom requirements.



EVOLUTION 7405

- Machining dimensions in X direction: 3200 mm (without additional support)
- Workpiece passage: 1200 mm
- Fully automatic positioning of suction cups



EVOLUTION 7402

- Machining dimensions in X direction: 2500 mm (without additional support)
- Workpiece passage: 920 mm
- Automatically positioning vacuum system



PinJet – the Dowel Anchor System for the EVOLUTION

The simplest way to fully automatically insert 8 mm wood dowels.



4mat

Formatting on all 4 workpiece edges and surface machining.



Connect Package – for Free Selection of Connection Technology

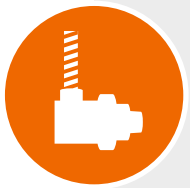

“Doors Ready” – For Complete Machining of Door Leaves

Consisting of a special angle drive for lock boxes and a lock box cutter to increase your CNC machining capabilities.



xcut Package – For Strip Processing

Simple. Efficient. Cost saving. From panel strips to finished furniture. With the xcut package the EVOLUTION automatically produces the required workpieces from panel strips previously cut in the longitudinal direction. This xcut mode completely eliminates cross-cuts otherwise required.

This makes the EVOLUTION 7402 and 7405 with optional xcut package a center for efficient carcass production.



CNC MACHINING CENTRES FROM HOLZ-HER

FOR UNIVERSAL MACHINING

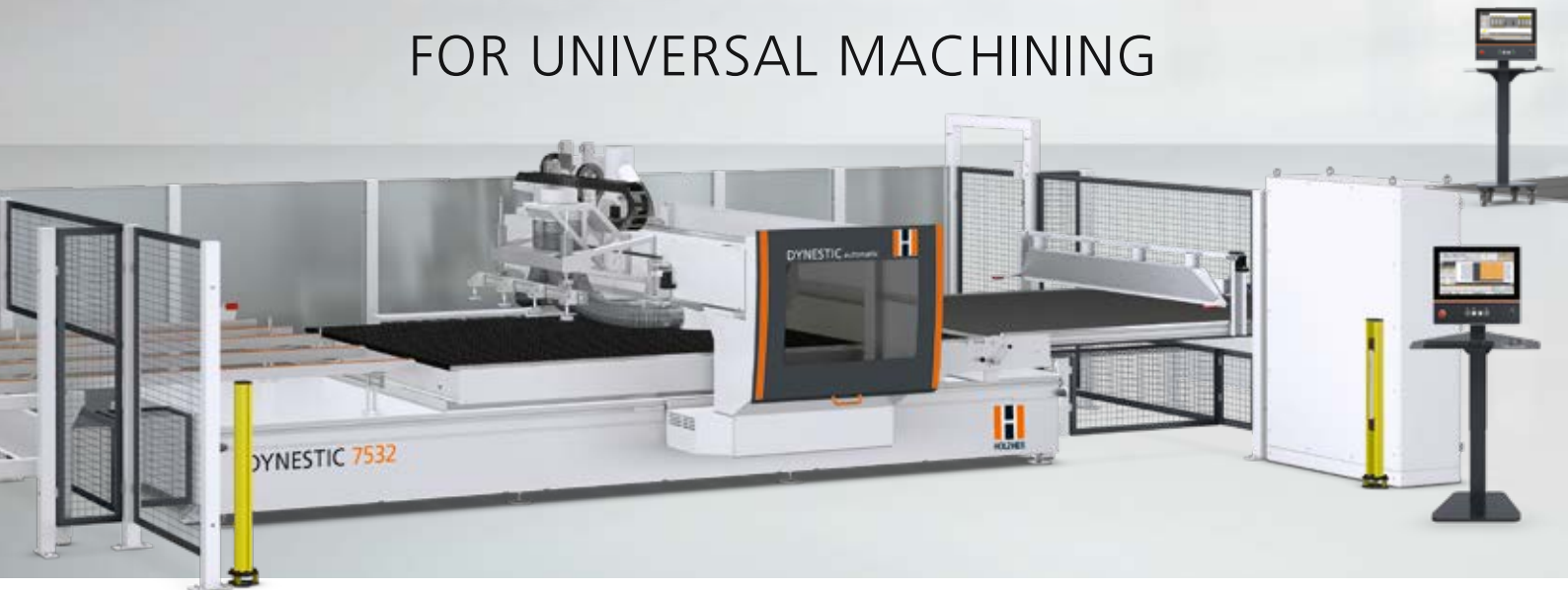

Space requirement

Simply entry into professional CNC machining with as little as 5 m² of space



DXF Import

Professional DXF import of components allows workpieces to be positioned on the work centre directly from CAD.



High Flow Nesting Table

The high flow nesting table provides optimum vacuum flow for up to 16 machining fields.

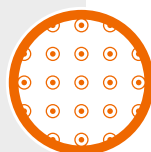

Modular system

The large modular system allows the CNC machining centers to be adapted to your challenges.



Software

User-friendly software as complete package with CAMPUS machine and office license.



Intelligent energy management

ECO mode – Intelligent energy management for HOLZ-HER CNC machining centres.





>
HOLZ-HER CNC
Machining Centres:
Strong Solutions to make
You Even More Formidable
in Competition.
<

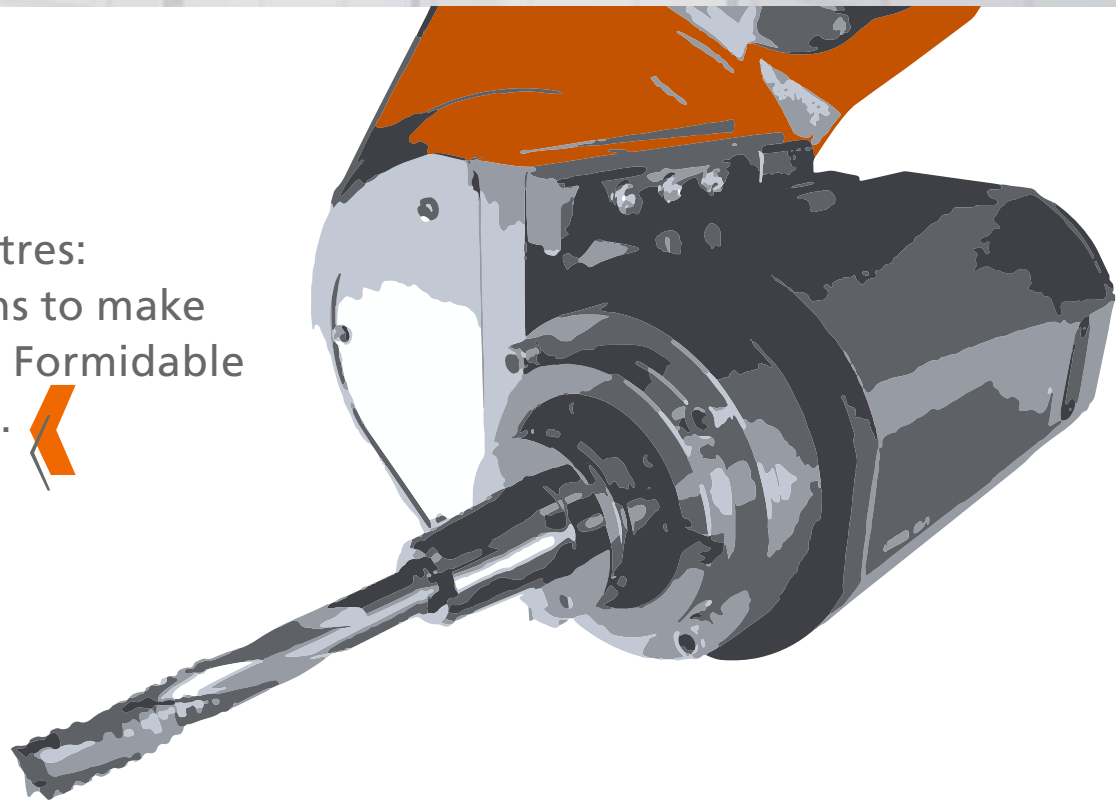

5x
 Up to
 5 CNC axes

🔄
 Flexible table
 concepts

↑ 300 ↓
 Extreme machining
 heights

⚙️
 Universal
 applications

📐
 Maximum
 precision



» Edgebanders from HOLZ-HER: Invisible Joints for all Edging and Professional PUR Processing

Edgebanders are pivotal for furniture with a high quality appearance. HOLZ-HER edgebanders concentrate on the essential features to unify compact design with a high degree of automation. The heart of any edgebander is the GluJet glue application system. HOLZ-HER always offers the perfect solution for every edgebander to ensure superior edging appearance with invisible joint technology.

- » ARTEA Series
- » STREAMER C Series
- » AURIGA Series
- » SPRINT Series
- » ACCURA Series
- » LUMINA Series

COMPACT, INVISIBLE JOINTS AND PUR PROCESSING; ALL AS STANDARD FEATURES

These compact models offer top equipment with invisible joints and PUR processing. As standard Jointing, gluing parts, corner rounding as well as a complete finishing area with radius scrapers, surface scrapers, buffers and sprayers all within minimum space

Small and Clever with Simple Operation

ARTEA 1020

- Edging thickness up to 5 mm
- Workpiece thickness up to 50 mm
- Feed 9 mm

ARTEA 1030

- Edging thickness up to 5 mm
- Workpiece thickness up to 50 mm
- Including corner rounding
- Feed 9 mm



VISE

DIGITAL LOGBOOK

VISE stands for VIsual SETting, a feature providing intelligent, visual support for machine operators. VISE serves as a digital logbook providing all settings for the digital counters and pressure gages to get your machine set up quickly and reliably.



High Tech and Convincing Performance Spectrum!

STREAMER 1054 C

- Edging thickness up to 8 mm
- Workpiece thickness up to 60 mm
- Feed 10 mm

STREAMER 1057 XL C

- Edging thickness up to 8 mm
- Workpiece thickness up to 60 mm
- Including corner rounding.
- Feed 10 mm



NC axis
package



THE STANDARD FOR MODERN CABINET MAKERS

Superior Expertise in Edgebanding

State-of-the-art servo-axes allow all setup operations to be completed without opening the machine hood. In this way, HOLZ-HER sets the standard for modern cabinet makers. Flexible for every edging trend with high-performance versions for fully automatic production.



With Clear Edging

The Glu Jet-iTronic solution includes an entire package of automated intelligence for highly varying applications on your edgebander. This reduces adjustment errors and reject parts to a minimum.

Just push a button to clean the gluing station perfectly. The monitor for the remaining glue quantity ensures that you always know how much more work you can complete. Whether thin edging or thick veneer edging – always the right power at the guillotine shears. The pressure combination at the pressure unit is always perfect.

Finally, to simplify operation, the equipment can be adjusted using intelligent, interactive graphic images. This makes sample workpieces a thing of the past.

No non-productive waiting times! *fa.s.t.* (set-up in the gap) enables you to run different machining processes at the same time on the edgebander. This process is extremely efficient in combination with the high speed NC servo-axes.

The multi-stage tools and revolving tool magazine allow the SPRINT to offer up to four different profile variants plus 8 mm flush cutter.

 An orange circular icon containing the text "Glu Jet" in white.

Glu Jet

 An orange circular icon containing the text "iTronic" in white.

iTronic



 An orange circular icon containing the text "*fa.s.t.*" in white.

fa.s.t.



SPRINT 1327

- Edging thickness up to 15 mm
- Workpiece thickness up to 60 mm
- Feed: 10–18 m/min
- Multiple profile milling technology
- Up to 17 NC servo-axes

SPRINT 1329

- Edging thickness up to 15 mm
- Workpiece thickness up to 60 mm
- Continuous multiple profile milling technology
- Feed: 10–18 m/min
- Up to 22 NC servo-axes



AURIGA 1308 XL power

- Edging thickness up to 8 mm
- Workpiece thickness up to 60 mm
- Feed: 10 m/min
- Up to 11 NC servo-axes



Available as:

„power“ version – with high performance standard features

„multi“ version – with multiple profile milling technology



Probes

All probes are specially coated and optimized for high gloss processing.

Clearance-free mechanisms

Blast nozzles

to blow off chips in the sensing areas.

Fully digital NC servo technology

With positioning accuracy of 5/1000 mm.

High precision linear guides

For precise adjustment of all devices.

High tech diamond cutters

With optimum chip removal.

Solid floor-mounted

Intelligent pneumatic control

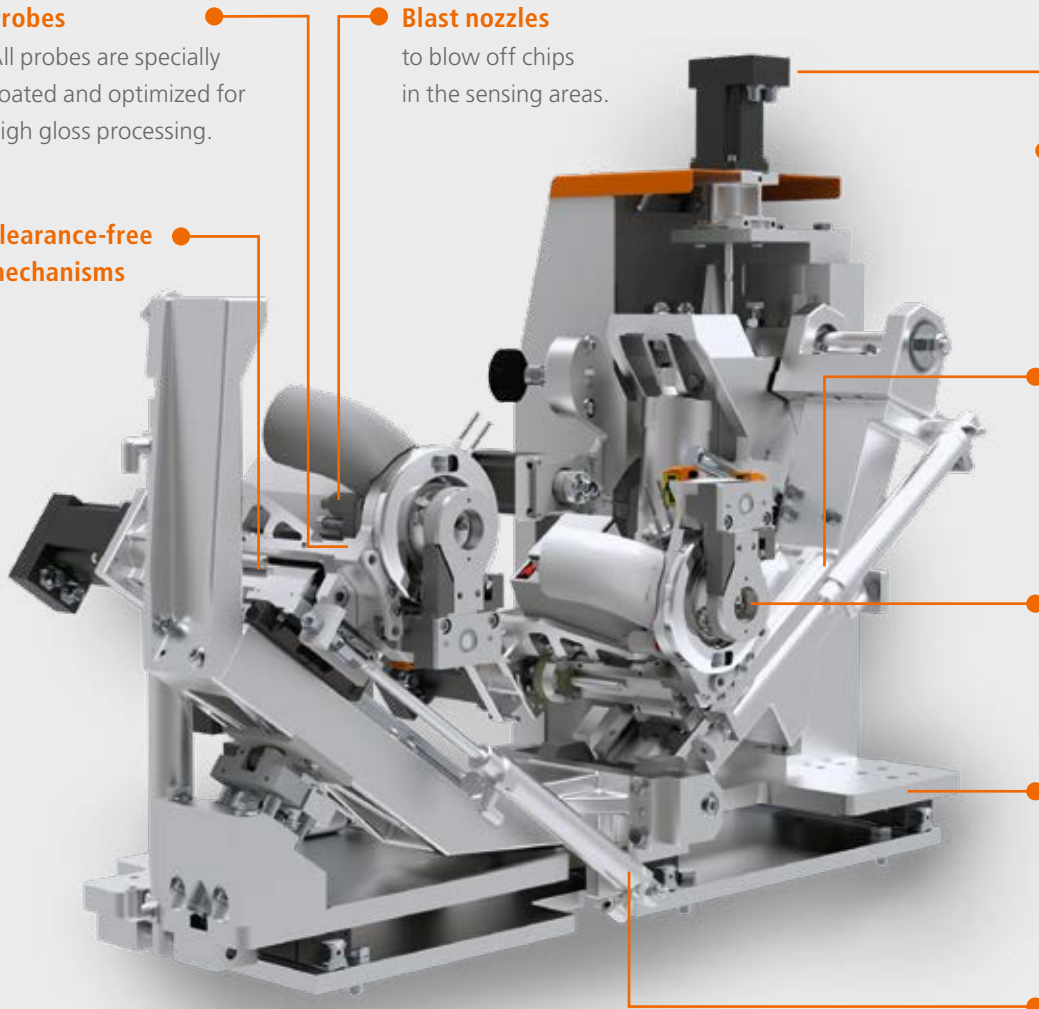

Robust, precise and repeatable two motor corner rounding unit

ACCURACY IN EVERY DETAIL

Units for 100 Percent Repetition Accuracy!

All units must satisfy maximum requirements right down to the last detail to obtain the same precision results repeatedly at high processing rates. The corner rounding

unit is an example of what is important. Because 100 percent repetition accuracy is highly significant for professional edgebanding.

Absolute Quality at Maximum Capacity

Edgebanders are paramount for furniture with a high quality appearance. Continuous development work on all equipment guarantees our customers maximum process reliability and increases their competitive ability. You can also benefit from 50 years of HOLZ-HER expertise in edgebanding.



ACCURA 1554

- Edging thickness up to 15 mm
- Workpiece thickness up to 60 mm
- Continuous multiple profile milling technology
- Feed: 10–25 m/min
- Glu Jet with iTronic



ACCURA 1556

- Edging thickness up to 20 mm
- Workpiece thickness up to 60 mm
- Continuous multiple profile milling technology
- Feed: 10–25 m/min
- Glu Jet with iTronic

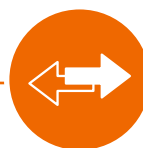

Available as:

„premium“ version – with two milling units

„grooving“ version – for vertical and horizontal grooving work

„flex“ version – with standard corner buffer unit



Glu Jet and LTRONIC

On the LUMINA users can change over from the Ltronic to the Glu Jet unit as required within minutes using the high precision HSK interface from our CNC technology. All stations have an automatic device detector for this purpose. Both systems provide a wide range of edging possibilities, without compromise, from state-of-the-art, high gloss edging right up to solid wood edging with large cross sections.

LT-Ready

LT Ready

Prepared for HOLZ-HER laser edging technology.

TWO WAYS TO OBTAIN PERFECT INVISIBLE JOINTS

Glu Jet and LTRONIC – as Double Pack for Perfect Invisible Joints!

The LUMINA series sets the highest standards offering a unique combination for panel processing: Two systems for perfect invisible joints. The Glu Jet glue application system for standard use of PUR glue and LTRONIC laser edging unit for perfect invisible joints with laser edging. In addition to our LTRONIC and Glu Jet systems, our

LUMINA series offers everything required for a professional edgebander. Up to 35 NC servo-axes for maximum automation of all machining units with exact repetition at the touch of a button. Even the pressure and glue quantity settings can be made fully automatically and adapted to the specific requirement.

LUMINA 1598 industry

- Edging thickness up to 20 mm
- Workpiece thickness up to 60 mm
- Continuous multiple profile milling technology
- Feed: 10–25 m/min
- Belt bridge with synchronous drive

Available as:

- „performance“ version – with corner buffing unit and free space for grooving unit as standard features
- „sanding“ version – with sanding attachment as standard feature





LUMINA 1380

- Edging thickness up to 15 mm
- Workpiece thickness up to 60 mm
- Continuous multiple profile milling technology
- Feed: 10–18 m/min

LUMINA 1594

- Edging thickness up to 15 mm
- Workpiece thickness up to 60 mm
- Continuous multiple profile milling technology
- Feed: 10–25 m/min
- Belt bridge with synchronous drive



Available as:

„**premium**“ version – with two milling units

„**grooving**“ version – for vertical and horizontal grooving work

„**flex**“ version – with corner buffer unit as standard feature

LUMINA 1596 industry

- Edging thickness up to 20 mm
- Workpiece thickness up to 60 mm
- Continuous multiple profile milling technology
- Feed: 10–25 m/min
- Belt bridge with synchronous drive



GLU JET – THE HEART OF OUR EDGE BANDER

Additional Value for You – An Invisible Joint with Every Edge and All Types of Glue!

Waterproof invisible joints with thin film technology

Industrial technology for small workshops – with the HOLZ-HER Glu Jet-system, you can always process PUR glue as standard, just as simply as EVA glue.

Persuasive arguments for you and your customers

- No additional glue pot as no glue pot is needed.
- No expensive nitrogen tanks.
- High strength joints for extremely long service life.
- PUR ensures heat and water resistance, providing quality benefits in all areas of cabinetmaking.

Invisible joints on all edges

The Glu Jet thin film technology means the glue penetrates deep into the panel structure. You get a high-strength joint and an invisible look at the same time.

■ A clean machine

The sealed system prevents the glue from burning, ensuring that it maintains its original color and does not emit any annoying adhesive vapors. Complicated, labor-intensive cleaning work on the glue pot and glue rollers is eliminated.

■ Just-in-time heat-up

From zero to operating temperature in only 3 minutes and back to zero just as quickly.

■ 100 % adhesive force at all times

Melting the glue as needed ensures that the glue always maintains its full adhesive force without losses resulting from repeated heat-up.



Glu Jet PUR 2K

The XL Glu Jet station allows users to process 2 kg glue cartridges, which are significantly less expensive than conventional PUR granules. This investment is clearly worthwhile for companies using over approx. 400 kg of PUR glue per year.



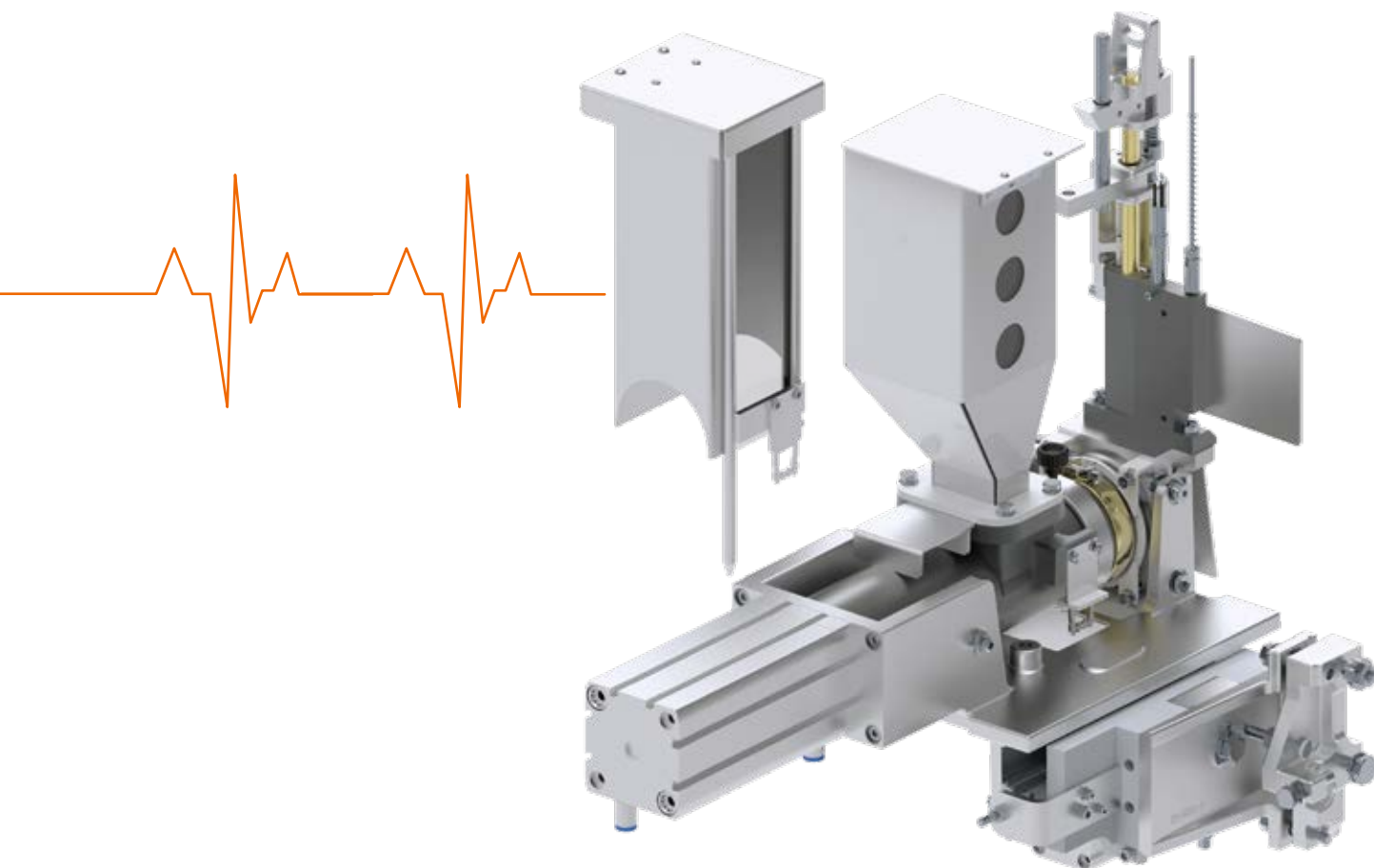

LTRONIC – Your Perfect Invisible Joint with Laser Edging

With the LTRONIC, you can process state-of-the-art laser edging silently, without heat-up time and without cleaning work for results with a perfect appearance. The NIR module in our LTRONIC unit can transfer heat energy quickly and precisely to the exact point where it is required, making it ideal for the activation of function layers on laser edging.

- **Immediate availability**
 No unproductive heat-up times whatsoever immediate availability at the press of a button.
- **LTRONIC operates without any noise emissions**
 whatsoever and without the use of compressed air.
- A highlight is the edging library completely integrated into the control. All of the very latest co-extruded and subsequently coated edging are already stored here as a factory-provided item and can be simply selected by the user via the standard touchscreen.



EDGE BANDERS FROM HOLZ-HER





WITH GLU JET THIN FILM TECHNOLOGY







SECURITY FOR THE FUTURE WITH THE GLU JET GLUE APPLICATION SYSTEM

All HOLZ-HER edgebanders are equipped with our patented Glu Jet adhesive application nozzle, guaranteeing you perfect invisible joints with all materials and making child's play of PUR processing. Professional edgebanding has never been so easy.

Perfectly Invisible Joints

 Glu Jet Glu Jet for clean operation	 100 PERCENT 100 % gluing force	 Invisible joints on all edges	 Just-in-time heat-up	 LTRONIC laser edging technology
--	---	--	---	--

Intelligent, Fast and Multi-Functional

 Multi-tool version	 =fa.st. Set-up in the gap	 iTronic Intelligent edging assistant	 Graphic setup aid	 VISE Digital logbook for all settings
---	---	--	--	---



Our quality promise to you!

To facilitate your decision in favor of Glu Jet, we are pleased to offer a three year warranty on the complete Glu Jet system as standard.



Clever Glue Change

- **White EVA glue**
for your economical light-colored edging
- **White PUR glue**
for your waterproof light-colored furniture
- **Neutral EVA glue**
for your dark-colored edging
- **Transparent PUR glue**
for your waterproof dark-colored edging



» HOLZ-HER Pressure Beam Saws: High-Performance Panel Cutting Technology <

The pressure beam saws from HOLZ-HER combine precision technology with intelligent software solutions for effective and accurate panel cutting. Whether craft shop or industrial facility, the wide range of equipment packages ensure that all HOLZ-HER saws can be optimally adapted to your specific application.

- » **LINEA Series**
- » **TECTRA Series**
- » **ZENTREX Series**

FROM CRAFTSMEN FOR CRAFTSMEN

Designed for everyone who needs high throughput with space-saving resource planning. Here the LINEA 6015 sets new standards for the economy class. Its flexible equipment variants make this saw the superior cutting solution for beginners as well as for high throughput for optimum cutting solutions. With its expressive layout, unique gantry design and universal linear guide concept, the LINEA 6015 is a match for the large pressure beam saws in terms of cutting results and handling. Whether your requirements are space, speed or gentle handling, the LINEA 6015 is a convincing machine for all sectors.



LINEA 6015

- Cutting Lengths up to 3100 mm
- Cutting Widths up to 3100 mm



Saw blade protrusion 68 mm



The LINEA 6015 Gives You Back Valuable Storage Space

The double sliding door integrated into the machine concept can be opened 1800 mm allowing free access to over 6 m² of usable storage space—from left or right—your decision.



THE SAW WITH THE HIGH PERFORMANCE SPECTRUM

The TECTRA series of pressure beam saws provide a convincing, high performance package. They are compact and therefore even fit in shops where work areas require extremely economic planning. Nevertheless, their cutting performance is far beyond standard.



Sägeblattüberstand
82 mm (classic) | 95 mm

TECTRA 6120

- Cutting Lengths up to 4400 mm

Available as:

"classic" version

- Cutting Widths up to 4250 mm

"power" version

- Cutting Widths up to 4250 mm

"dynamic" version

- Prepared for connection to storage
- Cutting Widths up to 6500 mm

"lift" version

- With lifting table as standard equipment
- Cutting Widths up to 4200 mm

Continuous Linear Guide Concept

Saw carriages, sawing units and rip fences are held precisely by ground V-guides preventing vibration. This ensures clean and precision cuts.

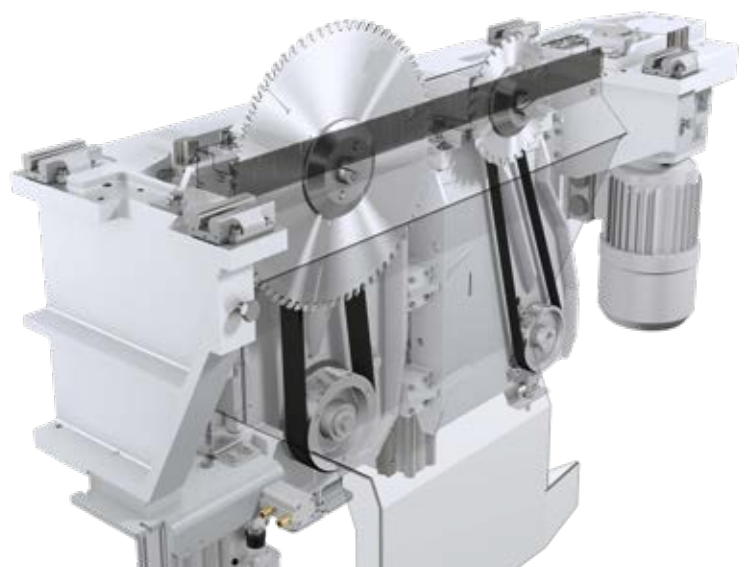

PERFECT CUTTING IN HIGH QUALITY CRAFT SHOPS WITH MASS PRODUCTION

High performance workshops frequently reach industrial levels. The ZENTREX 6215 was developed specifically for such user profiles. Solid design and powerful sawing units are typical features you can count on.

ZENTREX 6215

- Cutting Lengths up to 5800 mm

Erhältlich als:

„power“ version

- Cutting Widths up to 4250 mm

„dynamic“ version

- Prepared for connection to storage
- Cutting Widths up to 6500 mm

„lift“ version

- With lifting table as standard equipment
- Cutting Widths up to 4200 mm



Saw blade protrusion
115 mm | 130 mm (XL package)

Dust Control & Clean Protection

The two-stage extraction management system on the ZENTREX series provides support for every cut. Intelligent extraction flaps (dust control) with cutting plan control in the pressure beam and controlled, moving extraction hood (clean protection) directly in back of the saw blade always ensure maximum extraction performance for a clean machine table.



Laser Indicator

For panel sizes, whose length is difficult to differentiate from its width in spite of 3D simulation, the ZENTREX 6215 now offers a laser positioning system with accuracy down to the millimeter. Your advantage: Remeasuring panels or incorrect positioning in the machine is a thing of the past. Moreover, you minimize incorrect cuts and rejected parts.





The Lift Solution for Maximum Material Through-Put

Solid lifting table for exact positioning and high power mass production. Stacks with heights up to 1100 mm and weights up to 7 tons can be loaded with a fork lift, depending on version. High speed cycling times and high through-put for your production starting with panel thicknesses of only 4 mm.

Even wavy panels can be processed reliably with the lifting table. Select the suitable version for optimum integration into your production process.



FEEDING AND HANDLING SYSTEMS

FOR INDIVIDUAL AND EFFICIENT PRODUCTION



STATE-OF-THE-ART AND PROFITABLE LOADING OF PANEL CUTTING SAWS

HOLZ-HER panel storage systems offer fully automated and intelligent handling processes as well as highly efficient use of available storage space. Mature, fully integrated software with chaotic storage management increases production capacity enormously.

Profitable Add-On for Machines With Lifting Table

The lateral loading device for pressure beam saws with lifting table provides extremely high throughput rates and peak performance. Versions for installing on left, right or both sides. While one stack is being cut, the fork lift can load the next stack. This reduces idle times to a minimum while maximizing output.

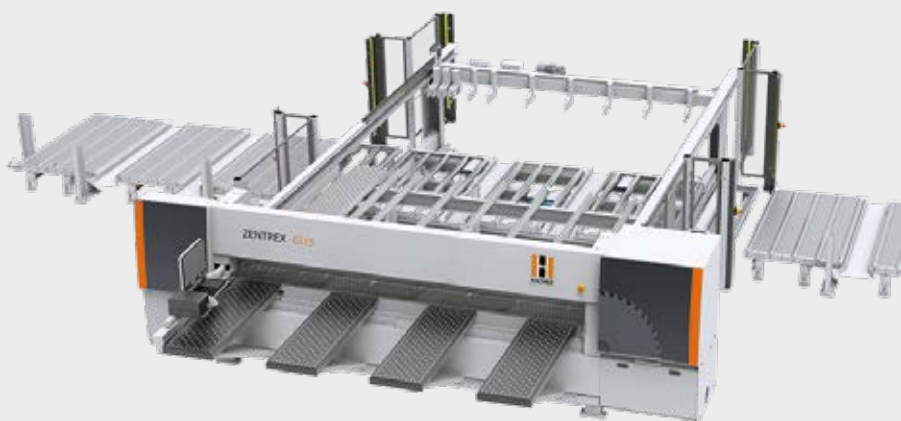



HOLZ-HER Vertical Panel Saws: Laid out for Absolute Cutting Precision

The SECTOR series vertical panel saws allow one-man operation from panel storage to finished, precisely cut component and are appreciated for their easy moving, ergonomic design. Equipped with a powerful sawing unit with up to 9.0 kW and saw blade diameter of up to 80 mm.

» SECTOR Series

SOPHISTICATED CUTTING PRECISION IN MINIMUM SPACE

The SECTOR 1254 vertical panel saw combines proven technology from over 60 years of experience with a basic, solid design offering you a unique price/benefit ratio. The range of applications for the SECTOR 1254 can be extended as required with

genuine HOLZ-HER accessories such as the patented HOLZ-HER SuperCut pre-scoring system – for tear-free edging quality on laminated panels.

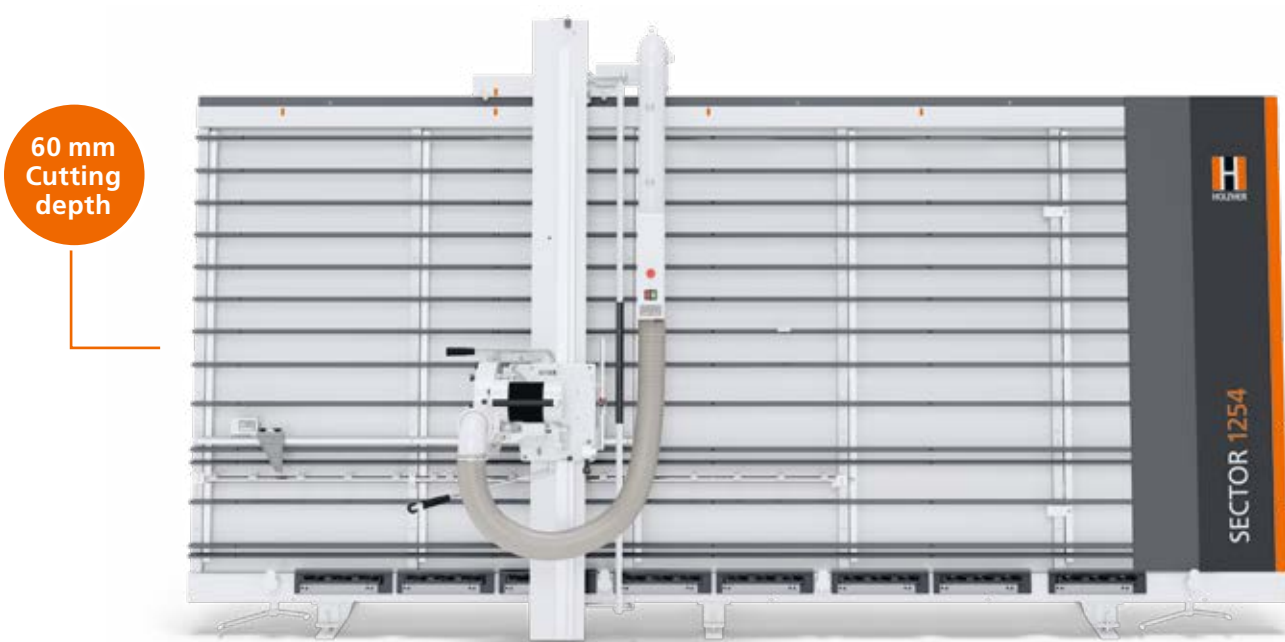

SECTOR 1254

- Cutting Lengths up to 5300 mm
- Cutting height 1900/2200 mm

SuperCut – Pre-scoring for Precision Cuts

SuperCut is the patented HOLZ-HER prescoring system. It provides ready-to-glue cuts with just one basic adjustment. SuperCut operates with two scoring blades to score laminated panels ensuring tear-free edge quality right down to one tenth of a millimeter. The result is a smooth edge for further processing.



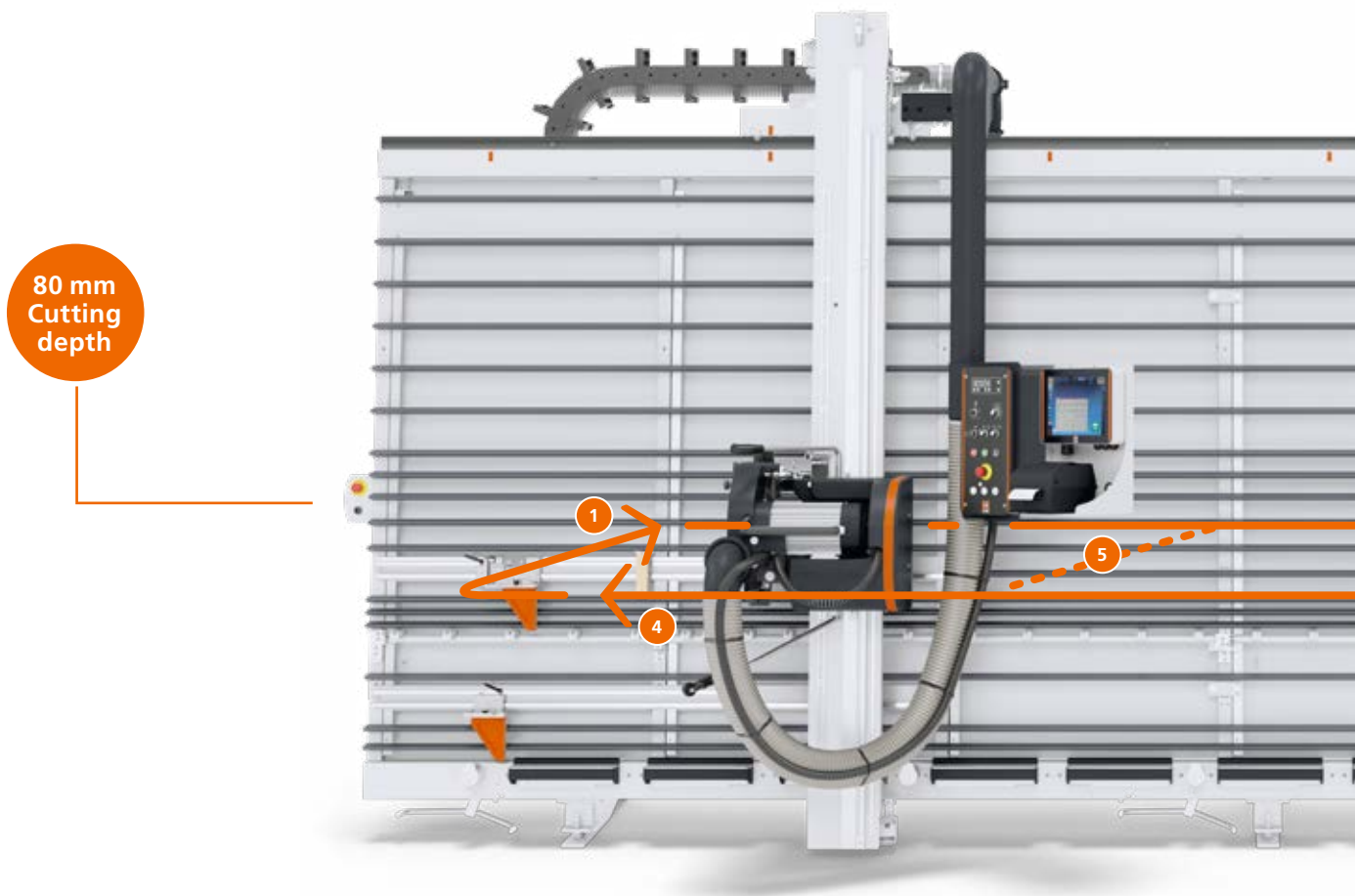

Maximum Performance – Minimum Space

Our panel saws have always been designed to produce finished cut quality for immediate edgebanding. Exact, tear-free cutting for your parts with accuracy right down to 1/10th mm. The machine's overall design, perfect ergonomics and other features have all been provided with absolute precision and quality in mind. With a footprint from as little as 5 m², this vertical panel saw is unbeatable in this area and saves you the cost of additional space. Professional cutting technology could not be more space-saving.

SECTOR 1255

- Cutting Lengths up to 7300 mm
- Cutting height 1900/2200 mm

SECTOR 1260 automatic

- Cutting Lengths up to 6300 mm
- Cutting height 1900/2200 mm
- Automatic version





AUTOMATIC VERSION

The SECTOR 1262 automatic offers an infinitely adjustable feed rate up to 25 m/min for automatic:

- 1 plunge cuts,
- 2 sawing through (horizontal or vertical),
- 3 retraction and
- 4 return to the operator at the touch of a button ensuring high speed cutting cycles.
- 5 **Optimized cycle**
If the entire cutting length is not required, the sawing unit returns to the middle of the machine.

SECTOR 1257

- Cutting Lengths up to 8300 mm
- Cutting height 2200 mm

SECTOR 1262 automatic

- Cutting Lengths up to 8300 mm
- Cutting height 2200 mm
- Automatic version



Panel Cutting with Cut Optimization

With the professional Opti-Base-V-Cut cutting optimization feature from HOLZ-HER, you always get the best optimization results for perfect material utilization. Clearly arranged user interface and 10" touch screen for simple, quick and intuitive operation and management of orders, material and parts lists. The label printer for HOLZ-HER machines included in the package ensures clear identification of all parts.

WITH HOLZ-HER

SMART WORKSHOP!

INTELLIGENT SOLUTIONS FOR EVERY SIZE BUSINESS



Small Craft Shops

Equipment:

- Furniture planning module
- Vertical panel saw with cutting optimization
- Edgebander
- Vertical CNC machining center

Output per shift: 160 to 200 parts
(corresponding to 1 standard kitchen)

Advantages:

- Small space requirement
- Low investment costs
- High flexibility



Workshop of the Future

Equipment:

- Carcass furniture module
- Nesting machining center
- Intelligent edgebanders

Output per shift: 200 to 300 parts
(corresponding to 2 standard kitchens)

Advantages:

- Low personnel allocation
- Low investment
- High productivity



**Medium Size
Craft Shops**

Equipment:

- Furniture planning module
- Automatic panel storage system
- Horizontal panel saw
- Automatic edgebander
- 5-Axis CNC machining center

Output per shift: 300 to 500 parts
(corresponding to 3 standard kitchens)

Advantages:

- Maximum flexibility
- High productivity
- State-of-the-art, digitized production



**Industrial
Craft Shops**

User-defined module constellation:

- Furniture planning module
+ production control
- Fully automatic material handling
- Cutting and machining centers
- Automated edgebanding
- Remnant return with unstacking station
- Robot cell solution

Output per shift: Customer-specific

Advantages:

- Customer-specific planning
- Maximum utilization of capacity
- Automated processes
- Maximum possible value creation

CAD/
CAM

Work Flow

HOLZ-HER's Automation Pro uses a standard interface for simple transfer of the production data from the standard design software to the HOLZ-HER Warehouse database. In addition to finished CNC programs in HOPS format or any other common WOP format, other processing data such as edging information is imported into the database via the CSV list.



Warehouse

In the overall Smart Factory system, Warehouse serves to actively process the complete range of parts to be transferred to production and then transfer them to the subsequent production processes. With Warehouse it is possible to import parts from any CAD/CAM system or from an ERP system via predefined interfaces or using freely defined import filters.



Produce

Just click the "Produce" button to automatically convert the job list in the background into nesting plans (for the CNC machine) and optimized cutting plans (for the pressure beam saw).



HHOS

Optimization of all cutting plans on beam saw



Better Nest

Automatic nesting and optimization of CNC nesting plans.



Preview

The preview feature allows all plans to be checked and, if necessary, modified before releasing for the machines.



Job lists

After the jobs have been released, they are stored directly as job lists on the machines in question.



Naturally Automation PRO continuously synchronizes the jobs and material in stock using HOLZ-HER's STORE-MASTER storage system.



2

Cutting

In the meantime, the pressure beam saw receives the jobs released in the Warehouse program and requests the appropriate panel material from the storage system. Intelligent 3D simulation provides the machine operator with clear instructions regarding the cutting sequence.

In the meantime, approved cutting plans from the job list are completed on the saw. Of course, it is possible to also cut entire stacks for serial production.

3

Nesting Work

The master computer transfers the corresponding jobs to the nesting CNC machine in the form of finished nesting plans. HOLZ-HER's nesting technology ensures efficient formatting and drilling on one machine. The great advantage of this production method is production of exactly formatted workpieces, already provided with groove or rebate in the rear wall and all required vertical holes for shelves, connectors, etc.

With the automatic version the machine can order the panel material and have it delivered directly from storage on an anticipatory basis.

Labeling

HOLZ-HER offers labeling systems matched precisely to customer requirements for marking workpieces. Manual and automatic solutions are available to match your production process.



4

Edgebanding

At the conclusion of the cutting operations and CNC machining, processing continues on the edgebander with bar code scanner. The barcodes on the labels ensure that the right programs and edging materials for the workpieces are called up on the edgebander without any manual intervention. The RETURN MASTER return system provides for an additional increase in efficiency.

5

Secondary CNC Machining

After edgebanding, some of the furniture parts require further CNC machining on the rear, or horizontal holes for dowels and connectors. With the label and barcodes the vertical CNC EVOLUTION can simply read out the QR code for the second CNC program. The right program for final processing then opens on the EVOLUTION.

6

viaCockpit The HOLZ-HER Machine Monitoring Program

Now, in addition to observing, monitoring and analyzing productivity on the master computer at the workplace, this is all possible at any time with a mobile device. The Weinig App-Suite and viaCockpit give you access to all important information on the status, notifications and irregularities in the system on your mobile device.

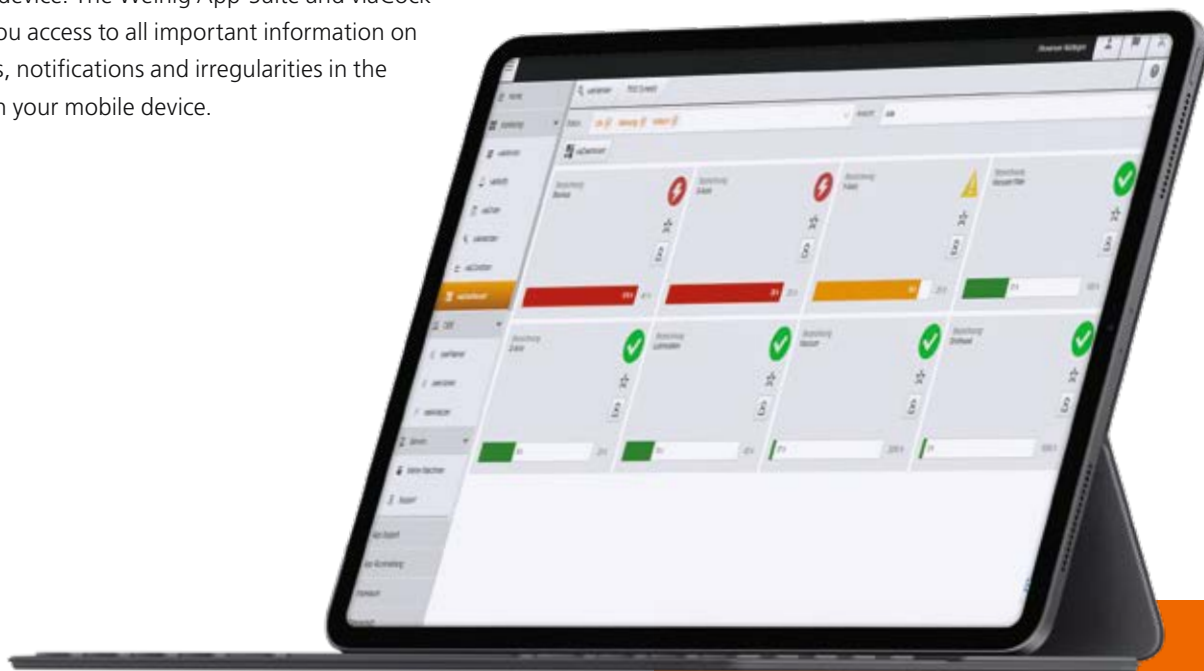

EXPORT



For detailed analysis of the data, pressing a button in viaConnector Edge allows you to export your collected data as a CSV file for transfer to an ERP or SQL database.



viaMonitor
for monitoring and
evaluation



viaNotify
reports any faults



viaOrder
provides an overview
of your production
progress



viaMaintain
notifies you when
service is due



viaCondition
Optimizes machine
utilization

THINK GLOBALLY – ACT LOCALLY

We offer our customers top service and maximum commitment at all levels of cooperation. In the after-sales sector, our comprehensive service concept guarantees that HOLZ-HER machines are reliable and efficient, right from the very start.

From professional installation and start-up, to intensive training by experienced HOLZ-HER experts, maintenance and, if required, repair, we are always at your side throughout the entire life of your machine. And we are almost always available for you at any time.

Our HOLZ-HER online support with direct access to your machine offers quick and effective solutions, worldwide. Our certified local agents speak your language and share their expertise with you and your employees, forming a strong partnership.

You can rely on us

To guarantee its comprehensive range of services, HOLZ-HER is represented worldwide with its own service offices. The service activities are controlled from our headquarters in Nürtingen as well as by our local offices. Our service offices worldwide:

- Australia
- China
- France
- Italy
- Canada
- Austria
- Switzerland
- Spain
- South-East Asia
- UK
- USA

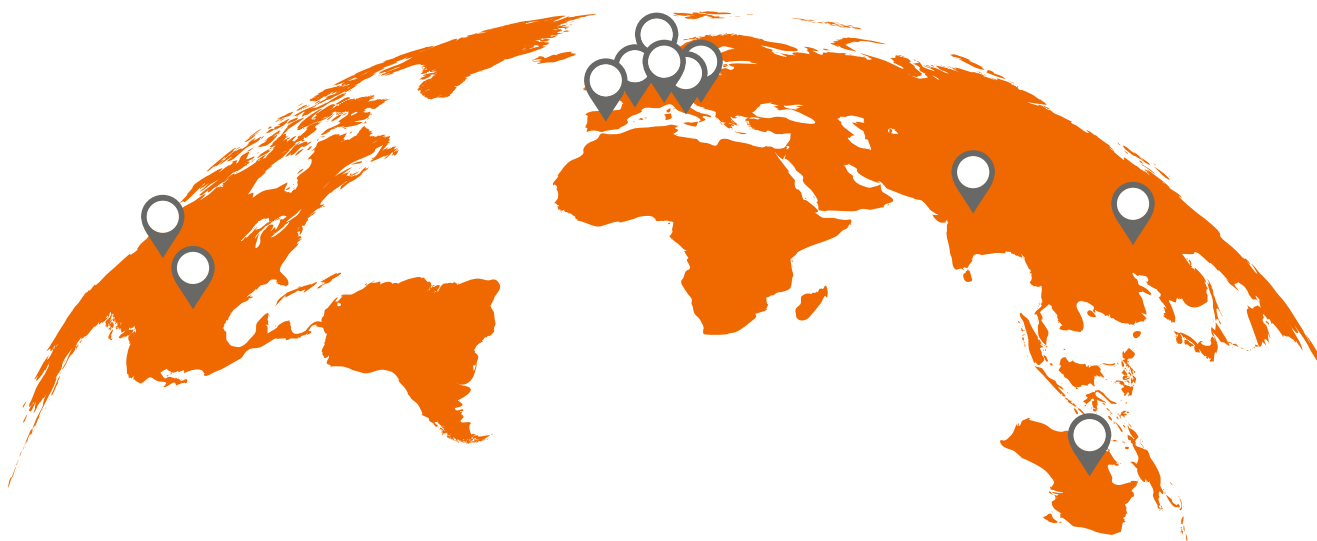



HOLZ-HER Service is Extremely Versatile to Meet the High Diversity of Our Customer's Requirements.

At HOLZ-HER service means much more than just a few telephone numbers. HOLZ-HER Services are backed by humans with a desire to share their enthusiasm for woodworking with others. And when experts talk to one another, solutions are not far away. This is why HOLZ-HER Services places great value on speaking with you, excellent training and regional customer proximity.

Versatile

- HOLZ-HER Service
- Contact person
- Parts supply
- Remote Access & Support

All information is available at:

www.holzher.com

HOLZ-HER GmbH

Großer Forst 4 | 72622 Nürtingen
sales@holzher.com | www.holzher.com



The technical data are guide values. We reserve all rights to changes in design and equipment, because HOLZ-HER machines are subject to continuous development. Illustrations not binding. Some of the machines shown also contain special equipment not included as a standard feature. For clarity, some of the machines are shown without guards.
Picture credits: P.3: TRUMPF Group; P.4: ©Shutterstock | Roman Samborski; P.15: ©AdobeStock | industrieblick; P.24/25,39/40: ©Shutterstock | silvae; P.27: ©Shutterstock | Roman Samborski; P.32: ©AdobeStock | pressmaster; P.43: ©AdobeStock | Bojan
EN – HOLZ-HER 1100 45 – Printed in Germany/Imprimé en Allemagne | Printed on: 28.10.2022 – First edition: 01.07.2022